

DESCRIPTION

Inneos' 880nm 12 Gbps VCSEL was designed for commercial operation from 0°C to 85°C to meet the needs of commercial, medical, and industrial applications. The device allows for wirebond assemblies to support a variety of packaging options.

FEATURES

- Operating temperature from 0°C to 85°
- Operation up to 12 Gbps
- Top-emitting
- Single channel

APPLICATIONS

- Transmitter Optical Sub-Assemblies
- Transceivers

ORDERING INFORMATION

PART NUMBER	DESCRIPTION
V880-12GSA-1THA	12 Gbps 880 nm VCSEL, Bare Die, 0°C to 85°C

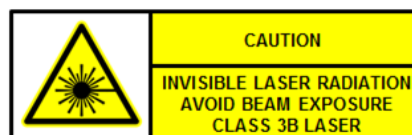
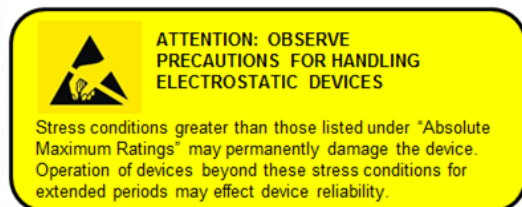

ABSOLUTE MAXIMUM RATINGS

PARAMETER	SYMBOL	MIN	MAX	UNITS
Storage Temperature Range	T _S	-55	125	°C
Operating Temperature Range	T _O	0	85	°C
Reverse Voltage	V _R		8	V
Continuous Forward Current	I _F		10	mA
ESD Protection (HBM)			100	V

OPTICAL/ELECTRICAL SPECIFICATIONS

PARAMETER	CONDITIONS	SYMBOL	UNITS	MIN	TYPICAL	MAX
Emission Wavelength	T=30°C @ 6mA	λ_c	nm	874	-	888
Variation of Wavelength with Temperature	-	$\frac{\Delta\lambda}{\Delta T}$	nm/°C	-	0.07	-
Spectral Width ^a	T _o =30°C @ 6mA	σ_λ	nm	-	-	0.6
Threshold Current ^b	T _o =30°C	I_{th}	mA	-	1.0	2.0
Average Operating Current		I_{avg}	mA	-	6	-
Operating Voltage	T _o =0°C @ 8mA	V_o	V	-	2.0	2.4
	T _o =85°C @ 8mA			-	1.8	2.4
Optical Output Power	T _o =0°C, 85°C @ 5mA	P_o	mW	1.0	-	-
	T _o =30°C @ 5mA			-	2.0	-
Small Signal Bandwidth ^c	T _o =85°C @ 7mA	f_{3dB}	GHz	9.0	-	-
Relative Intensity Noise ^d	T _o =85°C @ 7mA	RIN_{12}	dB/Hz	-	-	-128
Beam Divergence Half Angle (1/e ²) ^e	T _o =30°C @ 7mA	$\theta_{1/2}$	deg	-	15	-
Slope Efficiency ^f	T _o =30°C	SE	mW/mA	0.3	-	0.65
Differential Resistance ^g	T _o =30°C @ 8mA	R_{diff}	Ω	35	-	70

MECHANICAL OUTLINE

Dimensions are in microns.

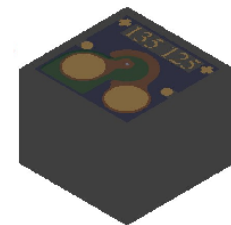
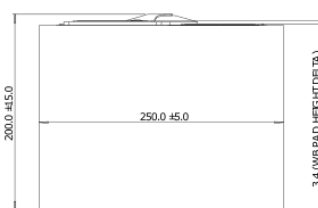
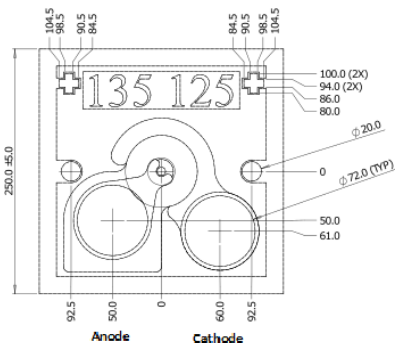

NOTES UNLESS OTHERWISE SPECIFIED:
 1. INTERPRET DRAWING IN ACCORDANCE WITH ASME Y14.5-2009.
 2. SUBSTRATE MATERIAL: GaAs.
 3. WIREBOND PAD MATERIAL: 1 μm GOLD.
 4. WIREBOND SHALL BE FULLY CONTAINED WITHIN BOND PAD OPENINGS.

ELECTROSTATIC DISCHARGE SENSITIVE DEVICE:
 FOLLOW ESD PROTECTIVE HANDLING PROCEDURES
 IN ACCORDANCE WITH ANSI/ESD S20.20-2014.

PARAMETER CALCULATION METHODS USED

a. Spectral width is calculated based on FOTP-127 where the spectral level of the measured spectra below 20dB from maximum value are made zero and RMS spectral width is calculated based on formula

$$\Delta\lambda_{RMS} = \sqrt{\frac{\sum_{i=1}^N P_i \lambda_i^2}{\sum_{i=1}^N P_i} - \left(\frac{\sum_{i=1}^N P_i \lambda_i}{\sum_{i=1}^N P_i}\right)^2}$$

where ‘ λ_i ’ is the wavelength and ‘ P_i ’ is the optical power level of the i_{th} point in the spectra.

b. The threshold current is derived by a linear fit method using 10% and 20% of peak optical power points. Threshold current is the point at which the optical power is zero using the linear fit.

c. The small signal bandwidth is obtained from optical response measurements at set current and reading the cut off frequency at which the power level is 3dB down from the power level at DC.

d. Relative intensity noise: RIN_{12} is the DC-RIN measured with -12dB return. The DC-RIN is measured using an electrical spectrum analyzer with resolution bandwidth set to 1MHz, calibrated photodetector and broad-band amplifiers. The RIN per unit bandwidth is calculated using the formula,

$$RIN \left(\frac{dB}{Hz}\right) = RIN [dBm] - 10\log_{10}(I_p^2 R_m) [dBm] - A [dB] - 10\log_{10}(\Delta f [GHz])$$

where ‘RIN’ is the peak RIN on electrical spectrum analyzer with resolution bandwidth ‘ Δf ’, ‘ I_p ’ is the measured photocurrent, ‘ R_m ’ is the input resistance of measurement system, and ‘A’ is the amplification.

e. Beam divergence half-angle is derived from measurement of optical power in far-field at various angles. The half-angle is the angular deviation from center where the power reduces by ‘ $1/e$ ’.

f. The slope efficiency is derived by linear fit method using 10% and 20% of peak optical power points. Slope efficiency is the slope of the lineal fit of optical power and drive current.

g. Differential resistance at point ‘ i ’ of the measured LIV is calculated based on formula,

$$R_{diff} = \frac{V_i - V_{i-1}}{I_i - I_{i-1}}$$

where ‘ V_i ’, ‘ V_{i-1} ’ are the measured voltages at set currents ‘ I_i ’ and ‘ I_{i-1} ’ respectively.